

Cylinder regulator R1400 Series

↘ *Stainless steel*

↘ *Ultra high inlet pressure*

↘ *Ultra high outlet pressure*

↘ *Single stage*



↘ This series of stainless steel single-stage ultra high pressure regulators is recommended for use with high purity gases and corrosive gas mixtures but excluding oxygen service. The regulator is specifically designed for a maximum inlet pressure of 415 bar.g and a maximum outlet pressure of 172 bar.g.

Specifications

Material

Body: 316L stainless steel
 Bonnet: nickel plated brass
 Seat: Teflon®
 Inlet filter: 316L stainless steel
 Gauge: 316L stainless steel,
 64 mm diameter
 Outlet valve: 316L stainless steel

Pressure/Temperature rating

Maximum inlet pressure: 415 bar.g
 Temperature range:
 -26 °C to +75 °C

Connections

Inlet: cylinder connection
 Outlet: 1/4 inch NPT male

Flow

CV=0.06
 The flow coefficient CV expresses the flow capability of the regulator.
 CV is the flow of air in standard ft³/min for each psi of inlet pressure

Design leak rate

Bubble Tight

Weight

1.8 kg

Installation dimensions

WxHxD: 220 mm x 140 mm x 125 mm

Design features

- Suitable for ultra high inlet & outlet pressures
- Inlet filter for maximum reliability
- Ultrasonically cleaned for high purity gas handling
- Individually tested and certified to assure maximum leak-tightness and reliability
- Outlet diaphragm valve for maximum safety
- Panel mounting facility using 2 threaded holes in the rear of the regulator
- High standard stainless steel finish

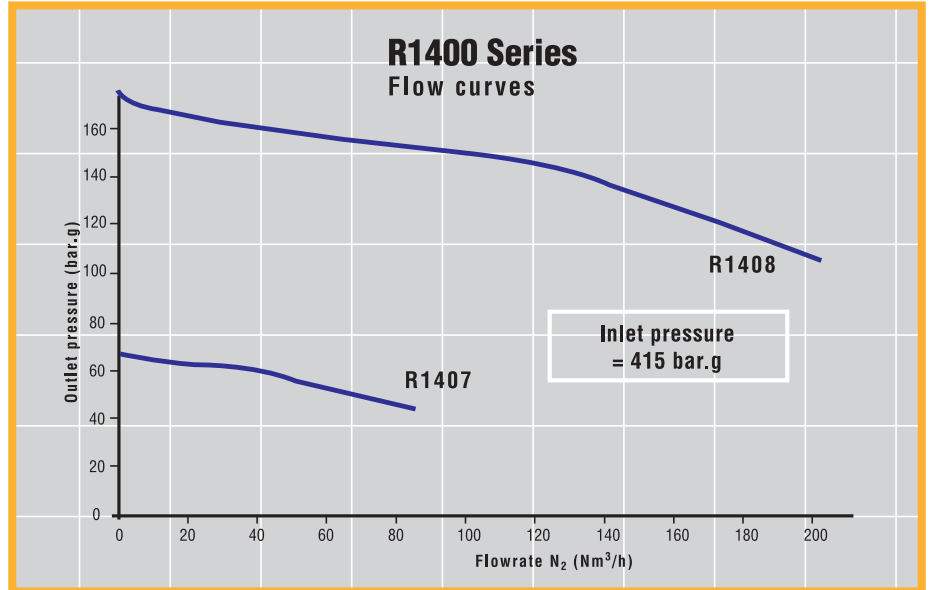
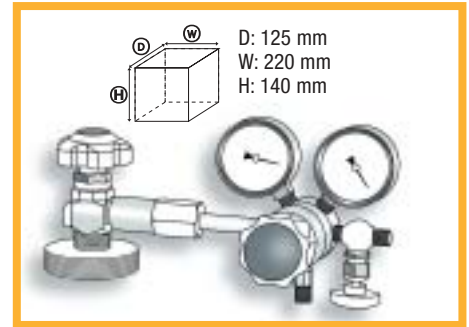

Ordering information

Order Code	Recommended outlet pressure range (bar.g)	Design capacity at maximum outlet pressure (*) (Nm ³ /h)	Inlet gauge range (bar.g)	Outlet gauge range (bar.g)
R1407	5 to 70	85	0 to 420	0 to 100
R1408	10 to 172	202	0 to 420	0 to 315

(*) For outlet pressure drops, refer to the flow curves.

OPTIONS

- D** Helium leak rate certification
- F** Extra 5 micron inlet filter
- G** Purge system (see datasheet)
- H** Compression fitting on outlet (available in various sizes)

Ireland
 Air Products Ltd.
 52, Broomhill Road - Tallaght - Dublin 24
 Tel. : +353 (1) 463 4242
 Fax : +353 (1) 463 4292
 E-mail : ordergas@airproducts.com
www.airproducts.ie

United Kingdom
 Air Products PLC
 2 Millennium Gate, Westmere Drive - Crewe
 Cheshire CW1 6AP
 Tel.: +44 (0) 845 777 8800
 Fax: +44 (1270) 614170
 E-mail: getgas@airproducts.com
www.airproducts.co.uk

tell me more
www.airproducts.com

© Air Products and Chemicals, Inc. 2004