

Cylinder regulator R400 Series



➤ **Brass**

➤ **High inlet pressure**

➤ **Single stage**

➤ This series of cost effective brass single-stage regulators is recommended for use with high purity, non-corrosive gases and gas mixtures up to 310 bar.g. The specially designed convoluted stainless steel diaphragm has no soft seal materials and so provides good regulating performance without contamination.

Specifications

Material

Body: brass
 Bonnet: nickel plated brass
 Seat: Teflon®
 Inlet filter: bronze
 Diaphragm: 316L stainless steel
 Gauge: brass, 64 mm diameter
 Outlet valve: brass

Pressure/Temperature rating

Maximum inlet pressure: 310 bar.g
 Temperature range:
 -40 °C to +74 °C

Connections

Inlet: cylinder connection
 Outlet: 1/4 inch NPT male
 Relief valve: 1/4 inch NPT male

Flow

CV=0.06
 The flow coefficient expresses the flow capability of the regulator.
 CV is the flow of air in standard ft³/min for each psi of inlet pressure.

Design leak rate

< 2 x 10⁻⁸ mbar.l/sec He equivalent

Weight

1.8 kg

Installation dimensions

WxHxD: 220 mm x 140 mm x 125 mm

Design features

- Inlet filter for maximum reliability
- Ultrasonically cleaned for high purity gas handling
- Relief valve fitted as standard for protection against over pressurisation
- Individually tested and certified to assure maximum leak-tightness and reliability
- Panel mounting facility using 2 threaded holes in the rear of the regulator
- High standard finish

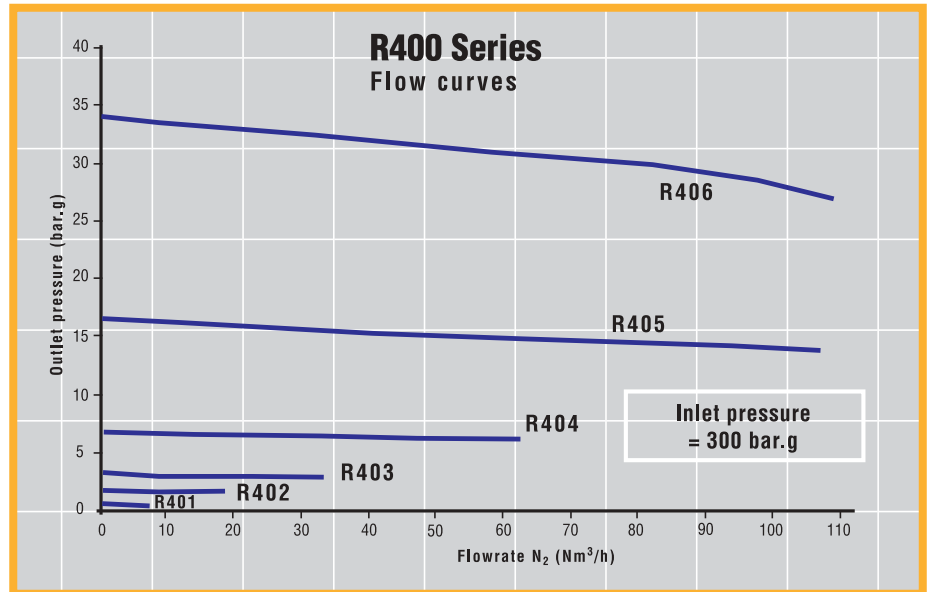
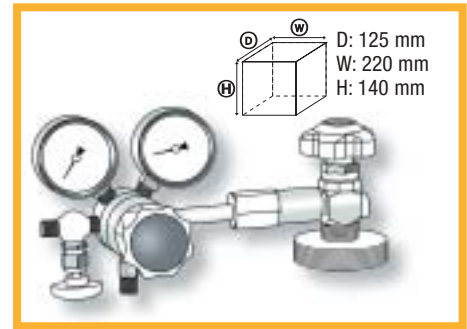

Ordering information

Order Code	Recommended outlet pressure range (bar.g)	Design capacity at maximum outlet pressure (*) (Nm³/h)	Inlet gauge range (bar.g)	Outlet gauge range (bar.g)
R401	0.1 to 0.7	7	0 to 315	-1.0 to +1.5
R402	0.2 to 1.7	18	0 to 315	-1.0 to +3.0
R403	0.5 to 3.5	33	0 to 315	-1.0 to +5.0
R404	1.0 to 7.0	62	0 to 315	-1.0 to +9.0
R405	5.0 to 17.0	106	0 to 315	0.0 to +25.0
R406	5.0 to 35.0	108	0 to 315	0.0 to +40.0

(*) For outlet pressure drops, refer to the flow curves.

OPTIONS

- C** Cleaning for oxygen service
- D** Helium leak rate certification
- E** Panel mounting kit, consists of 2 nuts
- F** Extra 5 micron inlet filter
- G** Purge system (see datasheet)
- H** Compression fitting on outlet (available in various sizes)
- M** Mounting on a back plate
- R** No relief valve

Ireland
 Air Products Ltd.
 52, Broomhill Road - Tallaght - Dublin 24
 Tel.: +353 (1) 463 4242
 Fax: +353 (1) 463 4292
 E-mail: ordergas@airproducts.com
www.airproducts.ie

United Kingdom
 Air Products PLC
 2 Millennium Gate, Westmere Drive - Crewe
 Cheshire CW1 6AP
 Tel.: +44 (0) 845 777 8800
 Fax: +44 (1270) 614170
 E-mail: getgas@airproducts.com
www.airproducts.co.uk

tell me more
www.airproducts.com

© Air Products and Chemicals, Inc. 2004