

# Safetygram #23

## Cylinder Valves

### Cylinder Valves

Most compressed gas cylinders require the installation of at least one valve. This valve allows the cylinder to contain gases and allows gas to be filled into or emptied from the cylinder. The cylinder valve is the most vulnerable part of the compressed gas package and requires a thorough understanding to maximize its performance. There are three basic valves used in the compressed gas industry: the pressure seal valve, the packed valve, and the diaphragm valve. There are several versions or designs within each of the three basic types. This pamphlet will address the more common valves in today's industry.

A working knowledge of cylinder valves can improve processes, save time and money, prevent problems, and improve the safety of your operation. This document must not be used as a guide for valve modification or repair. No modifications to valves are permitted and any repairs shall only be made by or under direction of the supplier.

**Table 1**

#### Basic Valve Rules

##### Always

- open valves slowly to control pressure surges and heat of compression!
- use the correct CGA connection for hook-up!
- inspect the valve for damage and foreign materials before connecting it to your equipment!
- ensure when the cylinder is not in use, even when empty, that the valve is in the closed position with the outlet seal in place and the transport cap is installed!
- consult your supplier if you have any questions regarding cylinder valves!
- make packing nut adjustments with the valve outlet depressurized!
- restrain cylinders!

##### Important

When returning any cylinder, ensure that the cylinder valve is properly closed, any outlet seals are in place and properly tightened, and the transport cap is correctly installed.

##### Never

- tamper with pressure relief devices!
- attempt to tighten or loosen the valve into or out of the cylinder!
- use a damaged valve where integrity may have been affected!
- continue to use a valve that operates abnormally, i.e., becomes noisy or progressively harder to operate!
- use an automatic operator, adapter, wrenches, or other tools to obtain a mechanical advantage on handwheel-operated valves without consulting your supplier first!
- lubricate valves or their connections!
- drag, lift, or move a cylinder using the valve or the handwheel as a handle!
- remove packing nuts on packed valves!
- adjust or tamper with retainer or bonnet nuts on diaphragm or pressure seal valves!
- use the cylinder valve to regulate flow or pressure!
- move cylinders without the transport cap installed!
- interchange transport caps between cylinders!



Figure 1

Pressure Seal Valve

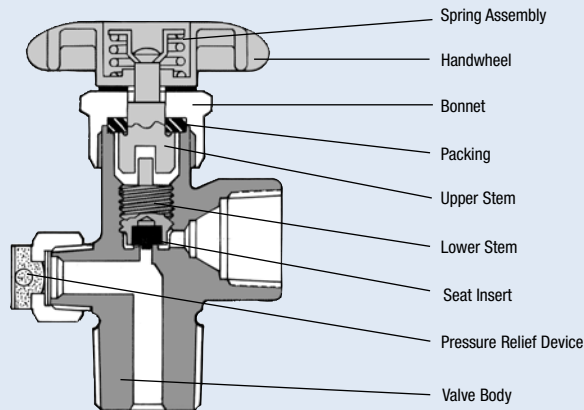

Pressure Seal Valve (Figure 1)

Products: Inerts, Oxygen, Hydrogen

Operating Principle: The pressure seal valve is a handwheel-operated valve using a two-piece valve stem. The upper and lower stems interface with either a key arrangement or a slot and blade configuration. The threads are located on the lower stem, and the upper stem is free-floating. A Teflon® material packing ring that makes contact with a ridge on the upper stem provides the seal around the valve stem. The force that provides this contact is a spring located in the handwheel. This spring provides an upward force to the upper stem and pulls the stem's sealing ridge into the packing ring.

Identifying Features

1. A spring in the handwheel can be detected by wiggling the handwheel. If a spring is present, the handwheel will pivot on the spring.
2. The valve has a nonrising handwheel. The handwheel is always in the same position relative to the valve body, regardless of whether the valve is in the open or closed position.

Recommended Opening Procedure: Air Products recommends pressure seal valves be used in the fully open or backseated position. Opening the valve fully causes the lower stem to ride upward on its threads until it contacts the upper stem and mechanically drives the upper stem's seal ridge into the packing ring. This improves the seal around the stem and helps to prevent packing leaks. Valves in the backseated position can be

Note: Teflon is a registered trademark of E.I. du Pont de Nemours and Company.

Figure 2

Wrench-Operated Packed Valve

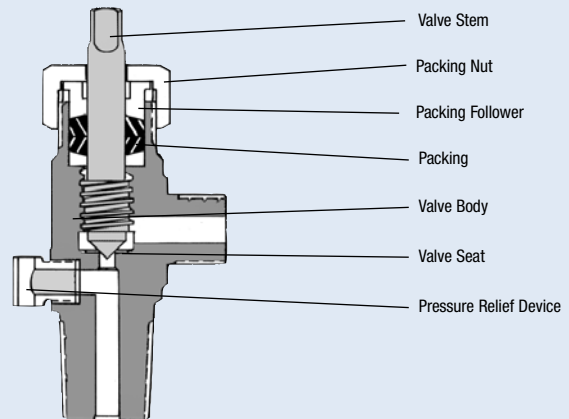

The Wrench-Operated Packed Valve (Figure 2)

Products: Corrosives and Reactive Gases

Operating Principle: The wrench-operated valve is a packed valve with a one-piece stem. The seat-to-stem seal is a metal-to-metal seal. The manufacturer's minimum recommended closing torque is 35 ft-lbs. This is much more than can be applied with hand force; therefore, the valve requires a wrench to provide sufficient closing force. The stem seal is accomplished by compressing a large ring of Teflon material between the valve body and packing nut, which forces the Teflon material to grip the stem.

Identifying Features

1. The valve does not have a handwheel. The top of the stem is machined square to accommodate a wrench.
2. The top of the valve has a large, internal-threaded nut screwed onto the body, where the valve's stem exits. This is the packing nut.

Recommended Opening Procedure: The wrench-operated valve has a very large flow capacity. It is not necessary to open this valve to the full open position to provide full flow to the process. Opening this valve fully poses two serious problems. The first problem is safety-related. In many applications, cylinders with these valves are used in tight quarters (e.g., gas cabinets) or behind barricades. These space constraints often prohibit the stem from being fully rotated when the valve is operating. This valve requires approximately three full turns from full open to full close. In the case of

mistaken as closed by inexperienced or untrained operators. When an operator checks a valve to ensure its position, he should always check by attempting to close the valve, never by trying to open the valve. If the valve was backseated using substantial effort, it is possible that the operator could think the valve is closed, when in fact it is fully open. Operators must be trained to use pressure readings or an equally reliable indicator to ensure that the cylinder valve is closed or open.

Recommended Closing Procedure: Close the cylinder valve tightly using a gloved hand. Air Products recommends always wearing gloves when operating cylinder valves. NEVER use wrenches or other persuaders to operate the valve.

Valve Advantages: The pressure seal valve is extremely reliable, very strong (used at pressures up to 6000 psig), economical, and user-friendly.

Valve Disadvantages: The valve is prone to leakage around the stem, especially inboard leakage when a vacuum is pulled on the valve outlet. Backseating helps minimize outboard leakage when the valve is in the open position. The threads on the lower valve stem are in the wetted gas stream. These threads are lubricated, and these lubricants can be an unwanted contaminant in high-purity applications.

Comments: This is a very reliable valve for non-corrosive and high-purity products. However, the design makes this valve inappropriate for corrosives and ultrahigh-purity products.

an emergency, it can take 15 to 30 seconds to close the valve, depending on space and operator stress. However, if the valve is opened to the recommended  $\frac{1}{4}$  to  $\frac{1}{2}$  turn, the valve can be quickly closed with minimal operator exposure. The second benefit of only opening the valve the recommended  $\frac{1}{4}$  to  $\frac{1}{2}$  turn is the protection of the upper section of threads.

The threads are in the wetted gas stream and, due to the corrosive nature of many of the products where these valves are used, the threads can become jammed with corrosion by-products. If the valve is opened to the recommended  $\frac{1}{4}$  to  $\frac{1}{2}$  turn and the threads become jammed, the upper threads usually remain clear. This allows the operator to further open the valve and to free the threads. The proper operation of this valve requires the use of the proper wrench. Air Products recommends using the square stem valve wrench, commodity code E99-P-38WRENCH, to operate these valves (except on highly reactive gases such as fluorine,  $\text{ClF}_3$ , etc.). This wrench has a square hole sized to fit the stem and an open-end wrench on the opposite end that fits the packing nut. The Air Products recommended opening procedure for this valve is as follows:

1. Connect the cylinder to the system.
2. Snug the packing nut with the wrench (35 ft-lbs).
3. Place the wrench on the stem and slap the valve open by striking the wrench with the palm of the hand.
4. Continue opening the valve until it is  $\frac{1}{4}$  to  $\frac{1}{2}$  turn open.

Where possible, leave the wrench on the valve so that a quick closing of the valve can be done in the event of an emergency.

**Recommended Closing Procedure:** Using an appropriate wrench, tighten the stem by pulling the wrench to the closed position. When the valve is closed as tightly as the wrench can be pulled, give the wrench a closing slap with the gloved palm of the hand. The minimum closing torque for this valve is 35 ft-lbs, but it is not uncommon for some valves to require as much as 60 to 80 ft-lbs to fully seal.

**Caution:** Some valves may become worn or collect debris in the seat, causing difficulty obtaining a complete seal. In these cases, it may require the use of two 12" crescent wrenches. The first wrench is placed on the flat sides of the valve body found 90° from the valve outlet. Care must be taken not to contact the pressure relief device on the back of the valve. The second wrench is then placed on the valve stem. Place the wrenches so

**Figure 3**

### Handwheel-Operated Packed Valve

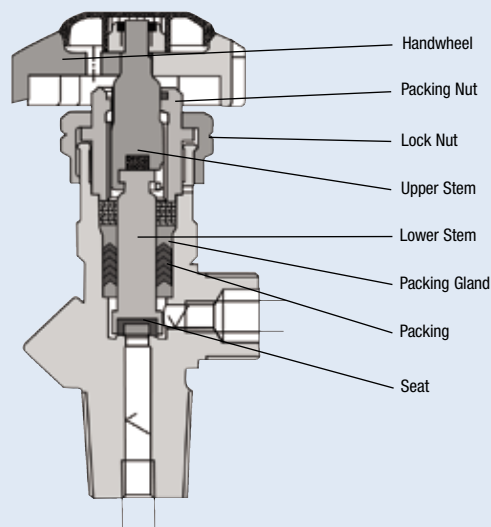

that you can pull them toward each other to exert closing force on the valve stem. The weak point of the valve is the stem where the wrench flats are machined. The stem will twist at this location at approximately 120 ft-lbs of force. If you feel the stem starting to twist, do not exert any more force. If you continue, you will break the wrench flats off the valve stem. If the valve does not completely seal, call the Emergency Response System for instructions for the next steps.

**Valve Advantages:** The valve is extremely rugged, and its one-piece stem provides positive operation. This strength and the metal sealing allow this valve to be used in the most severe services. The simple design makes this valve very reliable.

**Valve Disadvantages:** The nature of the products for which this valve is used is the main cause of problems with this valve. Corrosion products often deposit at the valve seat, preventing a seal, or they collect in the threads, making operation difficult or impossible. As the seat wears, increasing closing torque is required to seal the valve. The packing is also susceptible to both inboard and outboard leakage. This is caused by the same property that makes Teflon material such ideal packing: its ability to flow. When the Teflon material is squeezed, it responds by "cold flowing." This means the Teflon material pushes into every void in an effort to relieve the pressure. When this happens, a packing leak often develops. The packing should be checked frequently for leaks. Depressurizing the valve outlet and retorquing the packing nut can usually stop packing leaks. These weak points make this valve a poor choice for cylinders used in critical applications where cleanliness and ultra-high leak integrity are crucial.

**Comments:** A simple preventive maintenance program and good operating procedures can address and limit the disadvantages of this valve. Preventive maintenance in the form of weekly cycling to keep the threads clear and frequent checking of the packing for leaks is very beneficial. Good procedures for cylinder change-outs and proper operation are key in minimizing problems with this valve. The right wrench for valve operation also makes the operator's job easier and safer. Some wrench-operated valves, specifically those used in ammonia and amines service, have packing nuts with notches machined into the flats. This indicates that the nut has left-handed threads. Make sure you tighten these nuts in the counter-clockwise direction.

### The Handwheel-Operated Packed Valve (Figure 3)

**Products:** Corrosives and Reactive Gases

**Operating Principle:** The handwheel-operated packed valve can use metal-to-metal seats like the wrench-operated valve or elastomeric seats like the pressure seal valve. Unlike the wrench-operated valve, the sealing mechanism in this valve is designed to seal with only hand force. The packing is typically filled Teflon material. The packing is usually smaller and better contained than the packing in the wrench-operated valve. This helps to eliminate the packing leak problem associated with the wrench-operated valve. The packed valves used by Air Products employ a two- or three-piece stem in which the lower stem or spindle connects to the upper stem via a slip joint. In these valves, the stem tip seals against the seat without rotat-

ing. This reduces some of the wear and particle generation, as compared to the wrench-operated design. This sealing motion and a considerable reduction in seat size allow this valve to be operated using hand torque. The packing nut of this valve is secured by a lock nut with left-handed threads, which prevents accidental loosening of the packing nut.

### Identifying Features

1. The valve is equipped with a handwheel. The handwheel does not hold a spring and does not wiggle like the handwheel of a pressure seal valve.
2. The stem rises when the handwheel is turned to the open position.
3. Beneath the handwheel are two nuts attached to the valve body. The upper set of wrench flats belong to the packing nut, which is threaded into the valve body. The lower set of wrench flats belong to the locking nut. Note that these flats have notches machined into them. This indicates the locking nut has left-handed threads.

**Recommended Opening Procedure:** The slip joint interface of the upper and lower stems creates a free play of about ½ turn with this valve. In some instances when opening, especially with metal-to-metal seat valves, the handwheel will give an initial resistance and then suddenly turn about ½ turn with little resistance. At this point the valve is still closed. When the handwheel hits resistance again, this is the sealing force at the seat. The handwheel must be turned at least another ½ turn, or a full turn from initial start, for the valve to be opened. This handwheel rotates three full turns from closed to fully open. The flow capacity of this valve is much smaller than that of the wrench-operated valve; therefore, it may be desirable to open this valve fully. DO NOT backseat this valve. Open the valve fully and then rotate the handwheel clockwise about ½ turn. This position will provide maximum flow and allow the quickest closing in the event of an emergency. It will also eliminate the chance of an open valve being mistaken for a closed valve.

**Recommended Closing Procedure:** Close the cylinder valve tightly using a gloved hand. Air Products recommends always wearing gloves when operating cylinder valves. NEVER use wrenches or other persuaders to operate the valve.

**Valve Advantages:** The valve can be used in many of the same services as the wrench-operated valve. No threads or lubricants are in the wetted gas stem. The valve effectively seals at higher pressures with less closing torque than

Figure 4

### Spring-Loaded Diaphragm Valve (first generation)

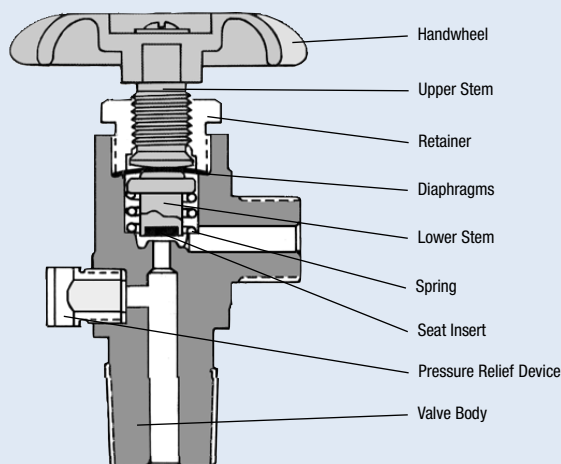

the wrench-operated design. The packing design provides greater seal integrity than other packed valves. The valve is hand-operated, thereby eliminating the need for special wrenches. The non-rotating lower stem eliminates much of the particle generation and wear associated with the wrench-operated packed valves.

**Valve Disadvantages:** Although this valve has better particle generation characteristics and leak integrity than other packed valves, diaphragm valves are superior to these valves in these attributes. The stem design makes this a very rapid opening valve, and it should not be used in services where gas velocity and adiabatic heat of compression are a concern (such as in oxidizer service). The dead band in the stem prohibits the use of any presently available separate pneumatic openers.

**Comments:** This valve is typically used to replace the wrench-operated valve in non-ultrahigh-integrity applications. In some applications where the consumer uses a yoke to connect to the cylinder, the valve is not equipped with a handwheel.

### The Spring-Loaded Diaphragm Valve (First Generation) (Figure 4)

**Products:** Highly Toxic Gases, High-Purity Gases, Rare Gases, and Pyrophoric Gases

**Operating Principle:** The diaphragm valve is a handwheel-operated valve, using a two-piece stem separated by nonperforated diaphragms. These diaphragms prevent leakage along the valve stem. The lower stem is encased in a spring, which forces the stem away from the seat when the

valve is opened. The upper stem is threaded into the diaphragm retainer nut. When the handwheel is rotated to the closed position, the upper stem pushes on the diaphragms, which deflect downward, forcing the lower stem against the valve seat. When the handwheel is rotated toward the open position, the upper stem is moved away from the diaphragms, allowing the spring to push the lower stem away from the seat. The replacement of elastomeric seals with metal diaphragms gives this valve superior leak integrity to the atmosphere.

### Identifying Features

1. The valve is equipped with a handwheel. The handwheel does not house a spring and does not wiggle or pivot.
2. The stem rises and lowers as the valve is opened and closed.
3. Beneath the handwheel is a hex-headed, externally threaded, diaphragm-retaining nut.

**Recommended Opening Procedures:** The diaphragm valve handwheel rotates about 1¼ turns from fully open to close. When opening a diaphragm valve, you will feel resistance for approximately one turn, at which point most or all resistance on the handwheel will disappear. At this point the upper stem has lost contact with the diaphragms. The valve should be opened to this point but not backseated. When the handwheel is free from resistance, the valve will provide maximum flow but will not be mistaken for a closed valve because the handwheel will turn freely.

**Recommended Closing Procedures:** The diaphragm valve can be difficult to close. When the valve is open, full cylinder pressure is exerted on the diaphragms. The diaphragms have a surface area of about one square inch. The pressure on this large surface area makes it difficult to push the diaphragms down. When closing the valve against cylinder pressure, about 60% of the closing force goes toward overcoming the gas pressure, while only 40% of the force is transmitted to the seat. Therefore, when a pressurized diaphragm valve is closed to the recommended 10 ft-lbs and the valve outlet is depressurized, the closing force on the seat is only 4 ft-lbs. Many diaphragm valves are either weeping through at this point or are just barely closed. Because of this effect, it is necessary to use a “double-close procedure” on these valves. This procedure requires the operator to close the valve as tightly as possible by hand (gloved hands are recommended), to vent the pressure in the valve outlet, and then to retighten the valve immediately. This is commonly referred to as double-closing. NEVER use wrenches or other persuaders to operate the valve. Use of these cheaters can permanently damage the valve components.

**Valve Advantages:** The replacement of elastomeric packing by metal diaphragms gives this valve superior leak integrity at the top works of the valve and stem. This is why shipping regulations require diaphragm valves on most poisonous gas cylinders. The valves have no threads or lubricants in the gas stream to generate particles or contaminate the gas.

**Valve Disadvantages:** The valve is difficult to close and requires the operator to double-close the valve. Because of this difficulty in closing, operators commonly use wrenches and other persuaders on the valves. To compound this problem, the valves do not withstand this abusive treatment to any great extent. The diaphragms may become permanently inverted, and the elastomeric stem tips can cold-flow down the throat of the valve. This plug of extruded elastomer can be lodged in the throat so tightly that even 2000 psig of pressure will not dislodge it. This valve does not function well in corrosive service. Because of its design, materials of construction, and surface finish, the valve is very prone to corrosion. What usually happens is that the spring corrodes to the stem and valve body and becomes immovable. This can happen in both the open and closed positions. The valve is also prone to open when exposed to vibration and shock unless it is properly closed and secured.

**Figure 5**

*Spring-Loaded Diaphragm Valve (second generation)*

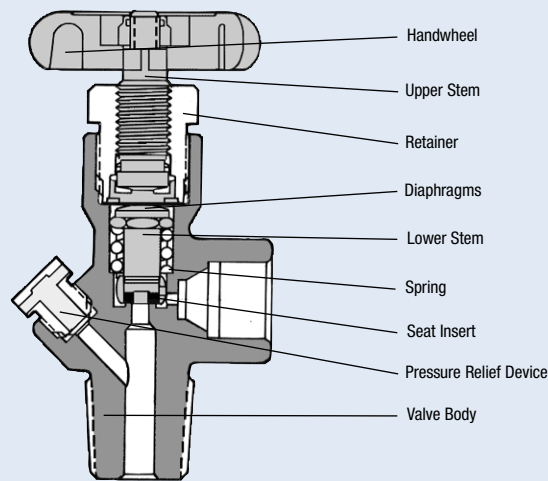

**Comments:** When using diaphragm valves or any valve with a soft seat material in a service where corrosion products can be produced, it is very important to take precautions to prevent those reactions. Corrosion products formed by these reactions can prevent normal valve operation and can become embedded in the elastomeric stem tip, preventing the valve from making a complete seal. When disconnecting cylinders with diaphragm valves, it is most important to double-close the valve and to properly install the outlet seal. Failure to use this procedure can result in release of the product into the environment.

**The Spring-Loaded Diaphragm Valve (Second Generation) (Figure 5)**

**Products:** All Products except Fluorine, High-Concentration Fluorine Mixtures (>20%), and Strongly Oxidizing Fluorine Derivatives

**Operating Principle, Identifying Features, Recommended Opening and Closing**

**Procedures:** Identical to those of the first-generation diaphragm valve.

**Valve Advantages:** Along with the advantages of the earlier diaphragm design, the second-generation valves incorporate features that provide additional benefits and flexibility. These valves are referred to as second-generation diaphragm valves because basic changes in the valve design have been incorporated to resolve the deficiencies of the earlier diaphragm valves. These changes include design of the wetted gashouse to provide better functioning, improved materials of construction,

and improved surface finishes. These changes enable this generation to be used successfully in corrosive service. The valve’s design prevents diaphragm inversion. The elastomeric stem tips are redesigned, usually in a “donut” configuration, to prevent the plugging extrusion problems of the earlier design. These changes also make this generation of valves cleaner from a standpoint of particle generation.

**Valve Disadvantages:** Although the improvements to this generation of valves eliminate the more serious problems of damage from abusive closing, they are not totally immune to abuse. These valves will also sustain damage when excessively torqued. This damage could include stem breakage or internal damage, which would preclude on-going use. These valves, like the earlier diaphragm valve designs, still include relatively large volume interiors with complex surfaces and are not fully optimized for cleanliness or purgability.

**Comments:** When working with these valves, it is very important to use good cylinder change-out procedures. These procedures must incorporate adequate purge and evacuation times to allow the valve interior to be properly cleaned. This problem becomes more critical if the valve is equipped with a restrictive flow orifice. Rapid purge and evacuation cycles are often ineffective in the removal of contaminants from these valves.

## The Tied-Diaphragm Valve (Third Generation) (Figure 6)

**Products:** Same as Second-Generation Spring-Loaded Diaphragm Valve

**Operating Principle:** The tied-diaphragm valve is a handwheel-operated valve, using a two-piece stem connected through the diaphragms. The metal diaphragms act as the seal at the top of the valve. The primary improvement in this generation of valves is the elimination of the spring used to open the valve. The lower stem is physically pulled away from the seat instead of being lifted away by the spring. This is accomplished by piercing the diaphragms and mechanically connecting the upper and lower stems. The point of penetration through the diaphragms is sealed by E-beam welding. When the upper stem rides up and down on its threads, it now moves the lower stem by a mechanical connection.

### Identifying Features

1. The valve is equipped with a handwheel. The handwheel does not house a spring and does not wiggle or pivot.
2. The stem rises and lowers as the valve is opened and closed.
3. Beneath the handwheel is one set of wrench flats on a nut threaded into the valve body. This is the diaphragm-retaining nut.
4. The valve has a threaded leak check port located on the side of the valve. This allows the diaphragms to be leak-checked.

**Recommended Opening Procedure:** The diaphragm valve handwheel travels about  $\frac{3}{4}$  turn from fully open to close. Because the stems have a mechanical connection, tied-diaphragm valves have a different feel than spring-loaded diaphragm valves. The upper stem is always attached to the diaphragms, so there is no “free-spinning” point. The valve should be opened fully but not back-seated. This will provide maximum flow but will not be mistaken for a closed valve because it is easily moved.

**Recommended Closing Procedure:** This new design does not solve the old difficulty in closing because the diaphragms are still affected by gas pressure. The diaphragm valve may be difficult to close. The reason for this difficulty lies in the design. When the valve is open, full cylinder pressure is exerted on the diaphragms. The diaphragms have a surface area of about one square inch. The pressure on this large surface area makes it difficult to push the diaphragms down. When closing the valve against cylinder pressure, about 60% of the closing force goes toward push-

Figure 6

Tied-Diaphragm Valve (third generation)

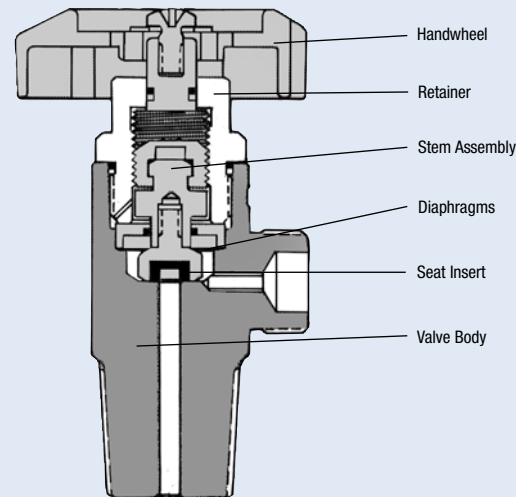

ing the diaphragms down, while only 40% of the force is transmitted to the seat. Therefore, when a pressurized diaphragm valve is closed to the recommended 10 ft-lbs and the valve outlet is depressurized, the closing force on the seat is only 4 ft-lbs. Most diaphragm valves are either weeping through at this point or are just barely closed. Because of this phenomenon, it is necessary to use a “double-close” procedure on these valves. This procedure requires the operator to close the valve by hand (gloved hands are recommended) and then vent the pressure in the valve outlet and reclose the valve immediately. Recommended closing torque is 8–9 ft-lbs (11–12 nm), not to exceed 9 ft-lbs (12 nm). This is commonly referred to as double-closing. NEVER use wrenches or other persuaders to operate the valve. Use of these cheaters can permanently damage the valve internals.

**Valve Advantages:** Along with the advantages of the spring-loaded diaphragm valves, tied-diaphragm valves incorporate features that provide additional benefits. A major benefit of the tied-diaphragm design is that it has a much lower internal volume, less surface area, and fewer complex surfaces in the gas path than other designs. These attributes make the tied-diaphragm valve more appropriate and successful for corrosive gas service. In all services, the tied-diaphragm valve is the most easily purged, particle-free valve design now in use. Antiextrusion stem tips and anti-inversion diaphragm configurations are incorporated in this design, eliminating those potential problems.

**Valve Disadvantages:** Like all diaphragm valves, tied-diaphragm valves can be difficult to properly close and require the same double-closure techniques that are used with spring-loaded diaphragm

valves. These valves can be damaged if significantly overtorqued and should never be operated with wrenches or persuaders. Tied-diaphragm valves have relatively small flow capacities. This is because the design limits stem lift. A consequence of this limited stem lift is that some elastomers used in the past with certain gases are no longer acceptable because the slight swelling they exhibit can slow or even stop the flow of gas through the seat. The low flow capacity also slows the filling of the cylinder. Usually a restrictive flow orifice, not the flow capacity of the valve seat, limits outlet flows. Some of the newer valves have been redesigned to increase stem lift and flow capacity.

**Comments:** Although these valves are the best available, they still require trained operators and good procedures to provide maximum benefit. Tied-diaphragm valves offer excellent performance potential for ultrahigh-integrity applications with corrosive, toxic, flammable, and mildly oxidizing gases. Like all cylinder valves, optimum performance requires knowledgeable operators and appropriate procedures.

### Pneumatically Operated Tied-Diaphragm Valves (Figure 7)

The tied-diaphragm valve is available in a pneumatically operated version for those who desire the capability of remote operation of the cylinder valve. The pneumatic version is identical to the manual version from the retaining nut down. The retaining nut and handwheel of the manual valve are replaced with a pneumatic actuator assembly. Compare Figures 6 and 7.

**Operating Principle:** The pneumatic valve is identical to the manual valve except in the mechanism used to operate the valve. The pneumatic actuator uses gas pressure to move a piston connected to the valve stem against a spring force that holds the valve closed. The valve can also be operated manually by the use of an optional manual opening device.

**Recommended Pneumatic Operating Procedure:**

The valve is connected to the system and the system is prepared to accept the product. This would include evacuation and purging of the system as well as a leak check. To operate the valve pneumatically or manually, the shipping lock must be released. To release the lock, turn the white knurled valve cap in the counterclockwise direction until the red button pops into the slot in the white knurled valve cap. The red button in the valve handwheel slot indicates the valve is now unlocked.

The valve, being a normally closed valve, is still in the closed position but may be opened by applying pneumatic pressure or by use of the manual operator.

To open the valve pneumatically, connect your gas supply to the actuator port on the top of the valve. The valve requires a minimum of 70 psig to open partially, 115 psig minimum to open fully, and 150 psig maximum pressure to the valve actuator. To open the valve, pressurize the actuator. The valve will remain in the open position as long as the pressure is maintained on the actuator.

The valve will close when the pressure on the actuator is relieved. The closing force is supplied by the springs that push the piston connected to the stem assembly in the opposite direction of the pressure. When ready to disconnect the cylinder, disconnect the gas line to the actuator and thoroughly purge the system of all residual product. Push the red button in so that the white knurled valve cap (shipping lock) can be turned in the clockwise direction. Tighten the shipping lock firmly with two hands to make sure the actuator is firmly locked. **DO NOT USE ANY WRENCHES OR OTHER CHEATERS TO TIGHTEN THE SHIPPING LOCK.**

The system should then be checked to ensure that the valve is closed before the disconnection is made. Immediately after the cylinder is disconnected, the outlet seal must be replaced and properly secured.

**Recommended Manual Operating Procedure:**

The valve is connected to the system and the system is prepared to accept the product. This would include evacuation and purging of the

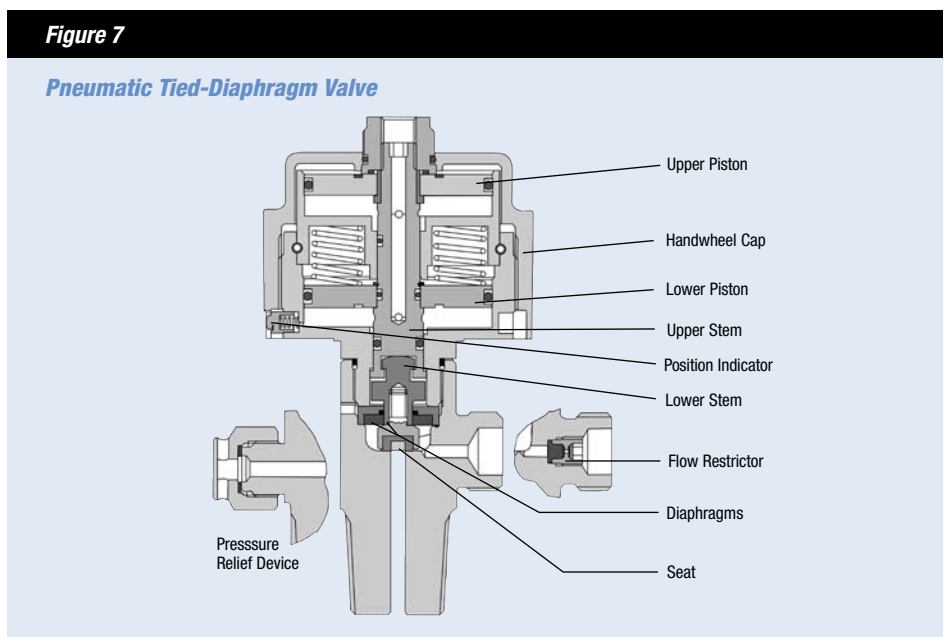

system as well as a leak check. To operate the valve pneumatically or manually, the shipping lock must be released. To release the lock, turn the white knurled valve cap in the counterclockwise direction until the red button pops into the slot in the white knurled valve cap. The red button indicates the valve is now unlocked. Connect the manual operator to the top of the valve where the gas line would attach. Screw the operator down with the handle or toggle in the vertical or upright position. The actuator must be installed firmly to function properly. Open the valve by pulling the handle to the horizontal position. To close the valve, return the handle to the vertical position. When ready to disconnect the cylinder, disconnect the actuator and thoroughly purge the system of all residual product. Push the red button in so that the white knurled valve cap (shipping lock) can be turned in the clockwise direction. Tighten the shipping lock firmly with two hands to make sure the actuator is firmly locked. **DO NOT USE ANY WRENCHES OR OTHER CHEATERS TO TIGHTEN THE SHIPPING LOCK.**

The system should then be checked to ensure that the valve is closed before the disconnection is made. Immediately after the cylinder is disconnected, the outlet seal must be replaced and properly secured.

**Valve Advantages:** The valve has all the advantages of the manual tied-diaphragm valve plus the ability to operate the cylinder valve remotely. Remote operation is very useful in minimizing employee exposure. The pneumatic operator eliminates the requirement for double-closing the diaphragm valve because the spring actuator applies a constant force to the seat.

**Valve Disadvantages:** As with the manual version of this valve, the pneumatic version has a small flow capacity. This limitation must be taken into consideration when determining how much product must be fed to the process. This valve can also be susceptible to pressurized valve outlets from seat leakage during transport if the shipping lock is not properly secured. Personnel operating this valve must be trained and made aware of the importance of properly securing the shipping lock before transport of the cylinder. Valves used in reactive gas service such as silane or hydrogen chloride may deposit by-products of reaction at the seat. These deposits may interfere with the seal of the valve seat and result in weep through the valve seat. Valves with PCTFE seats are soft enough to allow these particles to embed and cause leakage. So valves in certain of these services may use Vespel as the elastomer because it is hard enough to prevent these particles from embedding but still soft enough to allow for a good seal. Some elastomer seats may be susceptible to minor swelling in certain products. This was not an issue with valves with larger tolerances between the stem and seat but now can restrict or even stop flow. The shipping lock is vital in compensating for the pneumatic valves' susceptibility to leakage from compression of the spring from shock during shipping. It is also possible to inadvertently open an unlocked pneumatic valve by back-pressuring the outlet. This requires pressures that are above what most customer systems would experience, but it is a fault that all operators must be aware of.

**Comments:** Although these valves are the best available, they still require trained operators and good procedures to provide maximum benefit. If a valve does not seal, the shipping lock can used

to provide additional closing force to the seat. This should only be attempted under direction of the supplier. Any valve that undergoes this process must be tagged and the supplier notified so that the valve can be repaired or replaced.

## Second-Generation Tied-Diaphragm Valves

A new version of the tied-diaphragm valve is now available in the manual and pneumatic versions. This new design increases the flow capacity over the existing tied-diaphragm valves by 50%. Increasing the number of diaphragms to four and using materials of construction to improve diaphragm flexibility allow increased stem lift without compromising diaphragm life. In the pneumatic version, the shipping lock has been redesigned. The lock no longer covers the actuator. The lock is a blue knurled wheel that sits above the actuator

body. A lever with a red end extends from under the wheel. This lever replaces the red button in the original design. To lock the valve, the lever is depressed and the blue knurled wheel is tightened clockwise. To unlock the actuator, the wheel is turned counterclockwise until the lever pops into a depression in the wheel. When the lever is set into the slot on the bottom of the wheel, the actuator is unlocked and can be operated by gas pressure or manual operator.

### Valve Options

**Connections:** The tied-diaphragm valve and certain other valves are available with any of the standard cylinder valve connections or with the high leak integrity cylinder valve connections also known as DISS (Diameter Index Safety System) connections. See Safetygram 31, "Cylinder Valve Connections," for more information.

**Restrictive Flow Orifices (RFO):** An RFO is a small plug that screws into the valve outlet. It has a hole in the middle that can be anywhere between 0.006 to 0.16 inches in diameter. The purpose of the RFO is to restrict the amount of flow that can come from the cylinder in the event of a system failure downstream. There are recommended sizes for most products, but customers can specify their requirements. Many variables must be taken into account when determining the size of an RFO, such as pressure of product, reactivity of product, and flow required by the process. (See inset in Figure 7.)

### Emergency Response System

- Call: +1-800-523-9374 (North America)
- Call: +1-610-481-7711 (other locations)
- 24 hours a day, 7 days a week
- For assistance involving Air Products and Chemicals, Inc. products

### Product Safety Information

- For MSDS and Safetygrams, [www.airproducts.com/productsafety](http://www.airproducts.com/productsafety)

### Technical Information Center

- Call: +1-800-752-1597 (U.S.)
- Call: +1-610-481-8565 (other locations)
- Fax: +1-610-481-8690
- E-mail: [gasinfo@airproducts.com](mailto:gasinfo@airproducts.com)
- Monday–Friday, 8:00 a.m.–5:00 p.m. EST

### Information Sources

- Asia Industrial Gas Association [www.asiaiga.org](http://www.asiaiga.org)
- Compressed Gas Association [www.cganet.com](http://www.cganet.com)
- European Industrial Gas Association [www.eiga.be](http://www.eiga.be)

## For More Information

**Corporate Headquarters**  
Air Products and Chemicals, Inc.  
7201 Hamilton Boulevard  
Allentown, PA 18195-1501

**tell me more**  
[www.airproducts.com](http://www.airproducts.com)