

Safetygram #39

Chlorine Trifluoride

Warning: Improper storage, handling or use of chlorine trifluoride can result in serious injury and/or property damage. Use this product in accordance with the Air Products Material Safety Data Sheet (MSDS).

Introduction

Chlorine trifluoride (ClF_3) is a toxic, corrosive, very reactive liquefied compressed gas packaged in cylinders as a liquid under its own vapor pressure of 1.55 kg/cm² at 21°C (22 psia at 70°F). ClF_3 is a very useful chemical in operations requiring a high-energy fluorinating agent or incendiary material, especially since it can be handled at room temperatures. However, those same factors that make it quite useful also contribute to several high hazard potentials for the product.

Air Products has been the primary manufacturer and distributor of ClF_3 in North America for the past 35 years, and the compound represents one of the highest-reactivity products that Air Products currently manufactures or handles worldwide.

Lessons from History

Fluorine (F_2) has been recognized as the most powerful oxidizing agent of all known elements. Due to difficulties handling F_2 in its most reactive state (liquid), substitutes were evaluated in the late 1920s to find similarly reactive compounds with easier handling. Ruff and Krug successfully isolated ClF_3 in 1930 after experimental tests with chlorine monofluoride suggested the presence of a higher fluoride species.¹ Liquid ClF_3 is considered more reactive than vapor-phase F_2 reactions since more moles of fluorinating agent are present per unit area of reactant surfaces. Also, liquid ClF_3 may demonstrate even higher reactivity in certain circumstances than liquid F_2 because the F_2 liquid temperature is cryogenic, thus reducing its activity potential.

German interest in ClF_3 during World War II prompted the first industrial bulk production capability for the material. The Germans produced ClF_3 in tonnage quantities for military use in flamethrowers due the liquid's extreme hypergolic nature with fuels (self-igniting) and as a general incendiary material. Following the war, inter-

est in the use of ClF_3 for organic synthesis work increased although the material was eventually considered to be too reactive for practical use and mostly abandoned for these applications.² Synthesis reactions proved difficult to control and usually led to a wide variety of reaction by-products that were hazardous.

Many fluorinating compounds were evaluated as potent oxidizers for liquid-fueled rockets in the late 1940s through the early 1950s to overcome the storage and handling disadvantages of liquid F_2 . ClF_3 was first tested in the U.S. in 1948 on a liquid propellant rocket motor using hydrazine as the fuel. Additional testing yielded favorable results. However, all rocket materials of construction (including metals and seals) that could contact ClF_3 had to be scrupulously selected, cleaned, and passivated to prevent the components from burning during reaction.³ ClF_3 was also recognized as an extremely hazardous propellant due to its reactivity, toxicity, and toxic by-products of fluorination.

During the liquid rocket propellant era, a major incident involving ClF_3 occurred the first time a one-ton steel container was loaded with liquid ClF_3 for bulk shipment. The container had been cooled with dry ice to perform the liquid transfer and help make the product safer to handle, since the ClF_3 vapor pressure would only be about 0.007 kg/cm² (0.1 psia) in the subcooled state. However, the dry ice bath embrittled the steel container wall, which split while it was being maneuvered onto a dolly, instantaneously releasing 907 kg (2,000 lb) of cold ClF_3 liquid onto the building floor. The ClF_3 dissolved the 30 cm (12 inch) thick concrete floor and another 90 cm (36 inches) of gravel underneath the spill. The fumes that were generated (chlorine trifluoride, hydrogen fluoride, chlorine, hydrogen chloride, etc.) severely corroded everything that was exposed.³ One eyewitness described the incident by stating, "The concrete was on fire!"



In the 1990s the semiconductor industry began using ClF_3 in the cleaning process for certain chemical vapor deposition (CVD) tool chambers. In situ cleaning of the tool was desirable because the solid residues on the chamber interior were removed from the walls without dismantling the tool or risking personnel exposure to the hazardous residues or cleaning agents. It also yielded quicker turnaround time for the tool to resume wafer processing. The high reactivity of ClF_3 allowed the operation to be accomplished at relatively low temperatures, without requiring plasma or high temperature heating to dissociate it for use during the cleaning process. The use of vapor-phase ClF_3 for CVD chamber cleaning has demonstrated the ability to prolong chamber component life through the lack of high temperature, plasma use, and tool dismantling requirements.

Because the use of ClF_3 in semiconductor applications had increased due to its excellent performance in tool chamber cleaning, Air Products decided to empirically test the reactivity of ClF_3 with materials of construction, personal protective equipment, contaminants commonly found in systems and equipment, and other materials that may come into contact with the product. This Safetygram discusses the results of these tests and provides current recommendations to those who are manufacturing, handling, and performing emergency response with chlorine trifluoride.

Safety Considerations

Health

Chlorine trifluoride is toxic by itself and also reacts with moisture to form a variety of other toxic and corrosive materials, including hydrofluoric acid. When the product escapes into the environment, it hydrolyzes with the moisture in the air or, in the case of human contact, with the moisture in the human body. Direct contact with ClF_3 vapor or liquid can result in a thermal burn in addition to the chemical burns produced by the hydrolysis products. See Figure 1 to see the result of direct product contact with a piece of raw chicken being used to simulate flesh.

Since hydrogen fluoride is the major product of hydrolysis, the health hazards associated with hydrofluoric acid (HF) can be considered as primary health hazards for ClF_3 . Medical treatment for hydrofluoric acid exposures is very specialized. Air Products' Safetygram-29, "Treatment Protocol for Hydrofluoric Acid Burns," provides detailed information on the health effects and treatment for HF. All users of ClF_3 should use copies of this Safetygram to educate their employees, emergency people and local medical providers so they

Table 1

Physical and Chemical Properties

Molecular Weight	92.447
Boiling Point (1 atm)	11.75°C (53.15°F)
Melting Point	-76.32°C (-105.38°F)
Gas Density (21.1°C)	3.913 kg/m ³ (0.2443 lb/ft ³)
Specific Volume (21.1°C)	0.2556 m ³ /kg (4.094 ft ³ /lb)
Specific Gravity (air = 1)	3.260
Vapor Pressure (21.1°C)	1.55 kg/cm ² (21.5 psia)
Critical Temperature	153°C (308°F)
Critical Pressure	57 atm (308 psia)
Appearance	Gas/colorless Liquid/pale green Solid/white

Odor varies with hydrolysis products; low concentrations are described as bleach-like while higher concentrations are described as acidic or suffocating.

Figure 1

Vapor and Liquid Release on Raw Chicken



may know in advance what is required to address these exposures in the way of supplies and treatment. It should be noted that hydrofluoric acid exposure requires immediate specific and specialized medical treatment. Not only can this strong acid cause burns, but also the fluoride ion can be quickly absorbed through the skin, attack underlying tissues, and be absorbed into the bloodstream. If inhaled in high concentrations, HF can cause obstruction of the airway and acute pulmonary edema.

Table 2 gives the exposure levels for chlorine trifluoride and hydrogen fluoride.

Reactivity

Chlorine trifluoride is hypergolic (will initiate the combustion of many materials without an ignition source) with many materials. It is extremely reactive with most inorganic and organic materials. These reactions can be very violent or in some cases explosive. Therefore, all materials that come into contact with chlorine trifluoride must be evaluated.

Hydrolysis

Chlorine trifluoride hydrolyzes rapidly with moisture to form mostly hydrogen fluoride along with hydrogen chloride, chlorine monofluoride, and a variety of oxyhalogen compounds. The oxyhalogens may include chlorine dioxide, chlorous acid, chlorine oxyfluoride and oxygen difluoride.

Table 2**Exposure Levels for Chlorine Trifluoride**

LC₍₅₀₎	299 ppm for 1 hour rat (death due to respiratory failure)
OSHA PEL	0.1 ppm Ceiling
ACGIH TLV	0.1 ppm Ceiling
NIOSH IDLH	20 ppm
AIHA ERPGs	ERPG-1 = 0.1 ppm ERPG-2 = 1 ppm ERPG-3 = 10 ppm

Proposed AEGL Values for Chlorine Trifluoride

Classification	10-min	30-min	1-hour	4-hour	8-hour
AEGL-1	0.7 ppm	0.7 ppm	0.35 ppm	0.09 ppm	0.04 ppm
AEGL-2	6.2 ppm	6.2 ppm	3.1 ppm	0.77 ppm	0.39 ppm
AEGL-3	81 ppm	27 ppm	14 ppm	3.4 ppm	1.7 ppm

Exposure Levels for Hydrogen Fluoride

LC₍₅₀₎	966 ppm for 1 hour rat
OSHA PEL	3 ppm TWA
ACGIH TLV	3 ppm Ceiling
NIOSH IDLH	30 ppm

Proposed AEGL Values for Hydrogen Fluoride

Classification	10-min	30-min	1-hour	4-hour	8-hour
AEGL-1	2 ppm	2 ppm	2 ppm	1 ppm	1 ppm
AEGL-2	95 ppm	34 ppm	24 ppm	12 ppm	8.6 ppm
AEGL-3	170 ppm	62 ppm	44 ppm	22 ppm	15 ppm

Figure 2**Vapor ClF₃ Exposure to Polyethylene Tubing, Clean and Used****Fire Potential**

Chlorine trifluoride is a strong oxidizer that can essentially decrease the ignition temperature of potential fuels, including materials of construction (e.g., metals) for ClF₃ systems. Furthermore, because of chlorine trifluoride's extreme reactivity, there is a high potential for contamination to serve as an ignition source. Friction between two materials can generate fine particles (contaminants), which may ignite from the heat generated. Contaminants in chlorine trifluoride systems potentially can burn with sufficient heat to propagate the ignition to system components.

Due to this fire potential, Air Products conducted extensive exposure tests on a variety of materials used in personal protective equipment, operating systems, building materials, and materials that chlorine trifluoride might contact in the event of a release. These materials were tested for exposure to both vapor and liquid phases of chlorine trifluoride. Throughout the tests, materials that did not react with ClF₃ were immediately compromised by the presence of contamination (see Figure 2).

Containers

Chlorine trifluoride is shipped as a liquefied compressed gas under its own vapor pressure of 1.44 atm @ 21.1°C (21.5 psia @ 70°F). Although transportation regulations permit the use of low-pressure cylinders (working pressure <40 atm or 600 psig), Air Products only uses high-pressure cylinders that provide an added measure of safety due to their increased ruggedness.

Cylinders

A typical cylinder is a hollow tube with a closed base that permits the container to stand upright. The opposite end is tapered to a small opening that is threaded to accommodate the installation of a valve. A threaded neck ring is attached to the threaded end to allow a protective cylinder valve cap to be installed.

Carbon steel is the primary material of construction for chlorine trifluoride. Air Products specially selects cylinders for their internal finish, internally blasts them to remove any residual scale and slag, and cleans them to oxidizer service requirements. Pressure relief devices are not permitted on chlorine trifluoride cylinders.

For more information on the safe handling of cylinders, see Air Products' Safetygram-10, "Handling, Storage, and Use of Compressed Gas Cylinders."

Figure 3

Manual Diaphragm Valve

Ceodeux Monel 400 Spring Loaded Diaphragm Valve for Chlorine Trifluoride Service

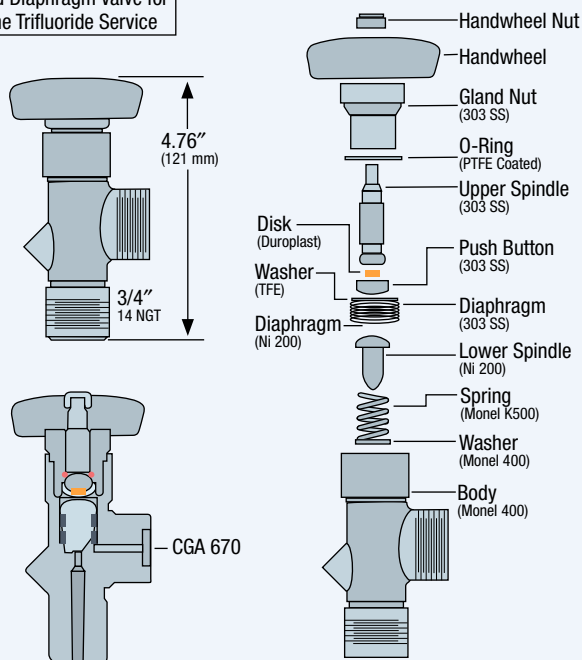
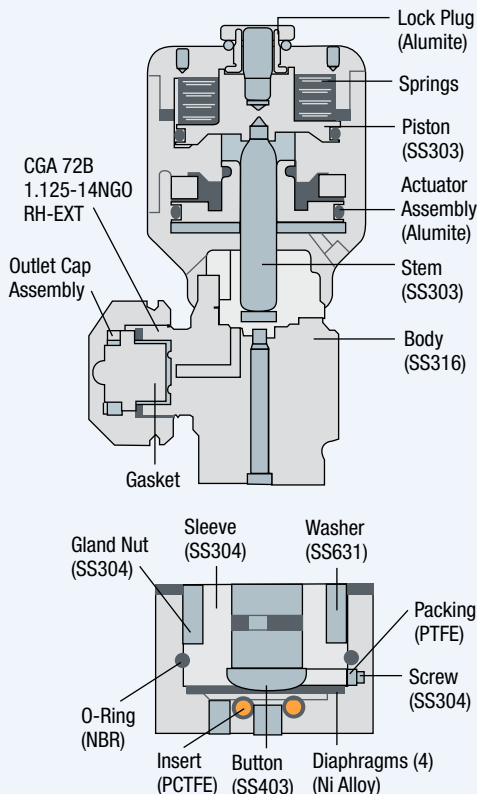

Figure 4

Pneumatic Diaphragm Valve



Valves and Connections

Valves

Containers in chlorine trifluoride service are equipped with one of several different valves. CP Grade cylinders are valved with an aluminum silica bronze wrench-operated valve while Electronic Grade cylinders are equipped with either a Monel spring-loaded diaphragm valve or a stainless steel pneumatic diaphragm valve designed specifically for chlorine trifluoride service. Cutaway drawings and valve details are available in the Air Products Safetygram-23, "Cylinder Valves," for the wrench-operated valve. The spring-loaded diaphragm and pneumatic diaphragm valves are of unique designs. Cutaway pictures of these valves appear in Figures 3 and 4.

Valve Connections

Valve connections for chlorine trifluoride vary by country. Table 3 lists some of the connection standards used in various countries.

For more information on cylinder valve connections, refer to Air Products' Safetygram-31, "Cylinder Valve Outlet Connections."

Table 3

Valve Connections

USA	CGA 670	728 Ultra High Integrity (DISS) Connection has been adopted by ISO.
UK	BS 6	
France	NF P	
Japan	JIS A (22 R)	

Cylinder Storage and Handling

Cylinders of chlorine trifluoride and other compressed gases should be stored and handled in accordance with Compressed Gas Association Pamphlet P-1, "Safe Handling of Compressed Gases in Containers." For more information, refer to Air Products' Safetygram-10, "Handling, Storage, and Use of Compressed Gas Cylinders."

International or local regulations may require additional safeguards for storage or use. Personnel must know and understand the properties, proper uses, and safety precautions for the specific product before using the product or associated equipment.

Storage

Cylinders should be secured in an upright position and stored in a well-ventilated area protected from the weather. The storage area should be secure with limited access. The toxicity, reactivity and corrosivity of ClF₃ requires area monitoring for leakage where the material is stored and used. Storage area temperatures should not exceed 125°F (52°C) and should be free from combustible materials and ignition sources. Storage should be away from heavily traveled areas and emergency exits. Avoid areas where salt or other corrosive materials are present to prevent cylinder deterioration. Valve protection caps and valve outlet seals must remain on cylinders when not connected for use. When returning a cylinder to storage, the valve outlet seal must be installed leak-tight. Separate

full and empty cylinders. Avoid excess inventory and storage time. Visually inspect stored cylinders on a routine basis, at least weekly, for any indication of leakage or other problems. Use a first-in, first-out inventory system, and keep up to date inventory records. The use of "FULL," "IN USE," and "EMPTY" tags is highly recommended. Some locales require special planning when storage of ClF_3 exceeds a specific amount. Before purchasing ClF_3 , contact the local authorities to determine the requirements for the storage of this material. ClF_3 is typically stored in areas specifically designed for ClF_3 . Storage areas must be posted with the proper signage, such as NFPA 704 ratings.

Handling and Use

Use only in well-ventilated areas designated for ClF_3 . Use a suitable handcart designed for cylinder movement. Do not drag, roll or slide cylinders. Never attempt to lift a cylinder by its cap. Secure cylinders at all times during storage, transport and use. Use a pressure-reducing regulator or separate control valve to discharge gas from the cylinder. Never apply flame or local heat to any part of a cylinder. Do not allow any part of the cylinder to exceed 125°F (52°C). High temperature may cause damage to the cylinder. If user experiences any difficulty operating the cylinder valve, discontinue use and contact the supplier. Use an adjustable strap wrench to remove overly tight cylinder caps. To prevent accidental opening of the cylinder valve, never insert anything into the cap holes to assist in cap removal.

Ensure that the cylinder valve is properly closed, the valve outlet seal has been reinstalled leak-tight, and the valve protection cap is installed before returning to storage, moving or shipping the cylinder.

Disposal

Return unused product to the supplier for proper disposal. In process applications, gaseous chlorine trifluoride can be disposed of in either liquid or dry scrubbers. Dry scrubbers work well under normal operating conditions for small quantities of ClF_3 but are not recommended for large or emergency releases unless specifically designed. Scrubbers must be designed to withstand the heat generated in the event of a large release. For normal operation, it is recommended an inert gas be used as a diluent prior to product being introduced to scrubber. This will help disperse the heat of reaction. Wet scrubbers typically use caustic solutions, such as potassium or sodium hydroxide, as the scrubbing medium. Wet scrubbers handle the heat of reaction better, as well as neutralize the products of reaction. Disposal of liquid chlorine trifluoride is extremely hazardous and is not recommended.

System Design, Preparation and Operation

Chlorine trifluoride is a strongly oxidizing, toxic, corrosive liquefied gas at typical storage temperatures. It is normally packaged in specially cleaned and prepared carbon steel or stainless steel cylinders and is used as a vapor to limit its potential reactivity with system components and other materials. Unless special precautions are taken, ClF_3 should only be removed from cylinders as a vapor. Care must be taken to prevent its condensation in piping or other equipment.

Materials of Construction

Metals

Most metals are compatible with chlorine trifluoride at ambient pressure and temperatures, provided the metal is oxygen-cleaned and passivated prior to exposure. Passivation allows the formation of a thin metal fluoride surface that is resistant to further reaction with ClF_3 , and more importantly, allows a controlled reaction with any remaining contaminants left behind by imperfect cleaning. It is this protective metal fluoride layer that helps determine a metal's suitability for ClF_3 service. Some metals, such as molybdenum, titanium and tungsten, form fluorides that are relatively volatile. This makes these metals unsuitable for service with this product because the metal fluoride gradually volatilizes off the surface, exposing new metal to the gas. This results in excessive erosion of the metal.

Carbon steel, copper and stainless steel are acceptable at ambient temperatures. Brass is rapidly dezincified by hydrogen fluoride; therefore any moisture contamination or leak of product to the atmosphere will form hydrogen fluoride and rapidly attack the brass. If the potential for elevated temperatures exist, Monel and nickel are the metals of choice. Material selection becomes more critical in systems using ClF_3 in the liquid phase, as more oxidizer is available to contribute to a reaction.

Elastomers

Only fluorinated elastomers should be used in chlorine trifluoride systems, and only if a metal cannot be substituted. Cleanliness of these materials is critical, as any contamination can quickly compromise the material. It is recommended that elastomers not be used in service where they will be exposed to the liquid phase, since even these elastomers may deteriorate rapidly and possibly ignite at elevated temperature (130°C). Elastomers are more difficult to clean for oxidizer service because they can absorb the solvents or detergents used to clean them; therefore, all elastomers should be degassed after cleaning in a vacuum oven.

Most non-fluorinated elastomers show little or no resistance to ClF_3 . Others like Neoprene™, rubber, polyethylene and PVC have shown resistance during short exposures but are very susceptible to any contamination—the reaction of ClF_3 with the contaminant rapidly propagates to the elastomer.

Sealants and Lubricants

TFE tape is the most common sealant used on threaded connections in chlorine trifluoride service. It is important when assembling these connections not to expose the tape directly to the flow path. To avoid this, it is recommended the first thread be left uncovered.

Lubricants of any kind should be avoided, if possible. If a lubricant must be used, a perfluorinated type specially manufactured for use with fluorine products is required. Hydrocarbon-based lubricants must never be used in chlorine trifluoride service, and even approved perfluorinated lubricants must never be exposed to liquid ClF_3 .

System Preparation

Due to the potential for ignition, systems used for chlorine trifluoride must be very carefully cleaned to remove readily oxidized impurities and scrupulously maintained to prevent contamination. Cleaning agents must be thoroughly removed prior to introducing ClF_3 into systems (normally by extensive purging with high-purity nitrogen or other inert gas), as these agents can also become fuels in the presence of ClF_3 . Heating of system components during purging should be considered to ensure removal of low-volatility cleaning agents.

To minimize potential problems, users should avoid excessive use of mechanical connections (to limit potential leakage sites) and elastomers (to limit potential reactivity and contamination) in ClF_3 systems. Similarly, system valves incorporating metal seats should be used if possible to reduce the chance of ignition of elastomer seats. Chlorine trifluoride systems should be passivated before use with increasing concentrations of ClF_3 , fluorine, or a fluorine mixture. The system should be observed during passivation for unexpected overheating of any components that would indicate excessive reaction with the components.

System Operations

Employees working with ClF_3 should be specially trained to ensure they understand the system requirements and the physical and exposure hazards of ClF_3 and its reaction products.

Chlorine trifluoride systems must be kept dry to minimize corrosion and contamination from acids that will form on contact of ClF_3 with moisture.

When not in use, equipment should be depressurized and purged with dry inert gas. For extended out-of-service periods, equipment should be kept sealed under positive pressure with dry inert gas.

As with any hazardous gas cylinder, operators should confirm the cylinder valve is firmly closed before loosening the valve outlet seal to connect a cylinder to the system. The outlet seal should be loosened slowly to limit the release rate of any ClF_3 that may have leaked into the valve outlet. The same procedure should be used to disconnect the cylinder from the system, and the pigtail must be vented and purged thoroughly before loosening the connection.

When connecting new ClF_3 cylinders, care is needed to prevent contamination of the valve outlet connection, especially if a gasketed connection is used. New gaskets must be thoroughly degreased and dried prior to installation unless specially cleaned and packaged gaskets are used directly from the manufacturer. New cleanroom gloves or equally clean alternatives should be used to install replacement gaskets. Similar precautions must be taken when changing other system components to avoid introduction of easily ignited contaminants.

When ClF_3 supply cylinders are initially opened, the operator should always be prepared to quickly reclose the valve should any evidence of reaction, overheating, or leaks develop. If any uncertainty exists about the cleanliness of system components, the cylinder valve should only be opened to introduce a minimal amount of ClF_3 vapor and then immediately closed. This will limit the amount of ClF_3 available to sustain ignition if a problem develops.

It is very important that chlorine trifluoride system pressures be kept well below the ClF_3 vapor pressure at the temperature of the coolest component in the process. This will prevent the condensation of the ClF_3 vapors in the system (see Figure 5). This is primarily to avoid the heightened reactivity of liquid-phase ClF_3 in the system and to allow proper flow control. Use of an absolute pressure regulator is recommended whenever possible to control system pressure below the ClF_3 condensation pressure.

With its relatively high boiling point, chlorine trifluoride vapor pressure is low at typical use temperatures, which can result in unacceptably low system pressure and flow rates, especially from cylinders with little remaining inventory. If the supply cylinder is heated to permit higher flows, it is even more critical to protect against condensation in cooler downstream components. System heating can also be considered to prevent condensation; maintaining uniform heating throughout the system can be difficult.

Figure 5

Vapor Pressure of Chlorine Trifluoride

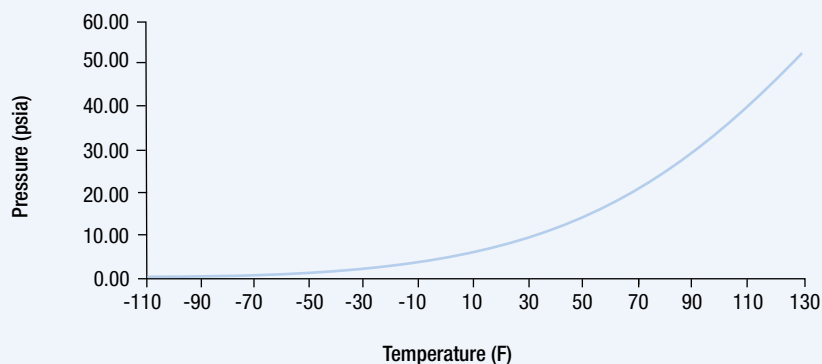

Prior to any maintenance, including supply cylinder changes, special care must be taken to ensure no hazardous quantity of ClF_3 remains in the equipment. Thorough purging with inert gas should always be done after the ClF_3 cylinder valve is firmly closed. If there is any suspicion of condensed ClF_3 in the system, the process should be heated and (ideally) evacuated to confirm no ClF_3 remains before the system is opened.

National and Regional Code Requirements

ClF_3 is a challenging material to properly manage from a code compliance and usage standpoint. This is because ClF_3 possesses both physical hazards (very strong oxidizer and very reactive) and health hazards (toxic and corrosive). The physical hazards of ClF_3 often cause local authorities to require the source containers be positioned remotely from the consumer's main facility or occupants. However, the low vapor pressure of the product at room temperature provides challenges to distribute the vapor any significant distance.

ClF_3 is classified as a "Hazardous Production Material" (HPM) per regional Code definition based on its NFPA 704 ratings (Figure 6).

An HPM is a solid, liquid, or gas associated with semiconductor manufacturing that has a degree of hazard rating in health, flammability, or reactivity of Class 3 or 4 as ranked by NFPA criteria. Also, an HPM requires that the material be used directly in research, laboratory, or production processes that have as their end product materials that are not hazardous (e.g., integrated circuits).

The physical hazards of ClF_3 often result in the local code authority establishment of low threshold or exempt quantities for the material. However, proper facilitation and usage of ClF_3 does provide a safe supply and distribution system if the hazards

Figure 6

NFPA Hazard Diamond for Chlorine Trifluoride

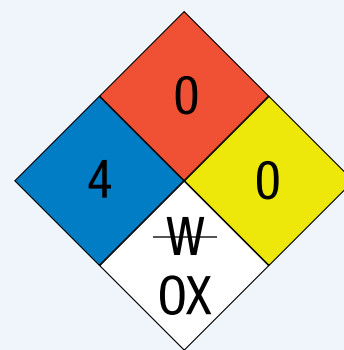

and code requirements are adequately addressed. One method to effectively manage ClF_3 hazards is through the use of properly designed and facilitated gas cabinets that are specially engineered to house ClF_3 cylinders and distribution control piping and components.

Gas Cabinet Supply Safety Considerations

When chlorine trifluoride is used in microelectronics facilities, consideration should be given to the following gas cabinet system design elements:

- Automatic sprinkler protection is not recommended for ClF_3 gas cabinets due to the potential for violent reaction with leaking ClF_3 (supported in 1997 by a major industrial insurance company's specific recommendations regarding ClF_3 gas cabinets for the semiconductor industry).⁴
- Pneumatically operated cylinder valves should be considered to allow automatic and immediate supply shutdown should there be a downstream incident.

Figure 7

Vapor ClF_3 , Exposure to Nitrile Glove, Clean and Oil-Contaminated



ER Notes

- PPE that comes into contact with liquid may ignite.
- Always assume that at least the outer gloves have been exposed to HF; exposure can cause burns.
- Knowing the limitations of PPE in emergency operations, responders should think about how they may come in contact with the material and minimize their exposure.

Figure 7 demonstrates the importance of clean PPE. Upon exposure to a stream of ClF_3 vapor, the new glove exhibits no reaction. The same glove, contaminated with a small amount of oil, instantly bursts into flame.

Table 4

Transportation Information

Shipping Name:	Chlorine Trifluoride
Hazard Class:	2.3
Shipping Label:	Toxic Gas, Oxidizer, Corrosive
Identification Number:	UN 1749
Description:	Chlorine Trifluoride, 2.3, UN1749

When shipping via common carrier, all cylinders must be secured in an upright position and be located at the rear of the trailer. Never load additional freight on top of the cylinders. For small cylinders, special shipping pallets are mandatory.

- A gas detector should be located in the cabinet to monitor and cause an automatic shutdown alarm on either hydrogen fluoride or chlorine dioxide indication.
- A heat or smoke detector should be located in the gas cabinet to monitor and cause an automatic shutdown alarm on an internal or external fire condition.
- The delivery pipe or tubing should be coaxial (double contained) with a monitoring alarm for loss of primary containment.

in emergency situations to minimize the chance of reaction of the product contaminants on PPE. Because the possibility of a reaction exists and the external PPE may melt if exposed to heat, natural fiber clothing should be worn under the PPE to minimize any melted material binding to the skin.

Cylinder Handling

Leather gloves, safety glasses with side shields and safety shoes are recommended.

Operations

Polycarbonate faceshield over safety glasses, PVC splash suit, inner gloves smooth leather, outer gloves 17-mil nitrile is recommended. All personal protective equipment MUST be clean and dry.

Emergency Use

Self-contained breathing apparatus (SCBA), totally encapsulating chemical protective suit (TECP), natural fiber clothing only to be worn under the PPE, smooth leather inner gloves and 17 mil nitrile outer gloves are recommended. Gloves and splash suit MUST be new. Earplugs should also be considered due to the possibility of a loud, vigorous reaction.

First Aid

As described under the “Health” section of this Safetygram, chlorine trifluoride is highly toxic and also reacts with moisture to form a variety of toxic and corrosive materials, including hydrofluoric acid. Medical treatment for hydrofluoric acid exposures is very specialized. Air Products’ Safetygram-29, “Treatment Protocol for Hydrofluoric Acid Burns,” provides detailed information on the health effects and treatment for hydrogen fluoride. All users of chlorine trifluoride should use copies of Safetygram-29 to educate their employees, emergency people and local medical providers so they may know in advance what is required to address these exposures in the way of supplies and treatment.

Emergency Response

For small vapor leaks, shut off gas flow by closing cylinder valve, using the appropriate PPE. Purge the residual vapor to a scrubber, using an inert gas. Repair the leak. Be sure to thoroughly inspect the area surrounding the leak for any signs of corrosion, which may require replacement of that part of the system. After the repair, the system must again be passivated.

For leaks at the cylinder or through the valve, isolate the cylinder and contact the Air Products Emergency Response System at: 800-523-9374 (in North America) or +01-610-481-7711 (all other locations)

In the case of a large vapor release or small liquid spill, immediately evacuate the area. If possible, without risk and while wearing appropriate PPE, stop flow of gas. Do not attempt any remediation! Call the Air Products Emergency Response System immediately.

Personal Protective Equipment (PPE)

General Rules

Because PPE may be compromised by the presence of dirt or water, PPE used in normal operations must be clean and free of contamination. In emergency situations where the product is leaking and response time is critical, the PPE must be as clean as possible to prevent reaction with the product. Therefore, only new gloves and acid-splash suits or totally encapsulating suits should be used

In the unlikely event of a large liquid spill, evacuate the area and immediately contact the Air Products Emergency Response System. **Do not attempt any remediation!**

Warning: Any attempt to neutralize a liquid spill may result in an explosion.

1. *Advances in Fluorine Chemistry, Volume 1*, Butterworth's Scientific Publication, 1960.
2. *Handling Hazardous Materials, Technology Survey SP-5032*, Washington, D.C.: National Aeronautics and Space Administration, Technology Utilization Division.
3. Clark, John D., *Ignition! An Informal History of Liquid Rocket Propellants*, New Brunswick, NJ: Rutgers University Press.
4. *Loss Prevention Data 7-7, Semiconductor Fabrication Facilities 17-12*, Factory Mutual Engineering Corp., 1997.

Emergency Response System

- Call: +1-800-523-9374 (Continental U.S. and Puerto Rico)
- Call: +1-610-481-7711 (other locations)
- 24 hours a day, 7 days a week
- For assistance involving Air Products and Chemicals, Inc. products

Product Safety Information

- For MSDS, Safetygrams, and Product Safety Information www.airproducts.com/productsafety

Technical Information Center

- Call: +1-800-752-1597 (U.S.)
- Call: +1-610-481-8565 (other locations)
- Fax: +1-610-481-8690
- E-mail: gasinfo@apci.com
- Monday–Friday, 8:00 a.m.–5:00 p.m. EST

Information Sources

- Compressed Gas Association (CGA) www.cganet.com
- European Industrial Gases Association (EIGA) www.eiga.org
- Japanese Industrial Gases Association (JIGA) www.jiga.gr.jp/english
- American Chemistry Council www.americanchemistry.com

For More Information

Corporate Headquarters
Air Products and Chemicals, Inc.
7201 Hamilton Boulevard
Allentown, PA 18195-1501

tell me more
www.airproducts.com