

PRISM[®] Membrane Dryers

PE3020 & PE3030

Membrane Dryers for Air and Gas

PRISM PE3020 & PE3030 membrane dryers deliver exceptional value and benefits to OEM customers and end users. Severe duty construction, solid performance, and exceptional lifetime, make the PE3020 & PE3030 membrane dryers the choice for industrial applications.



A typical membrane separator contains thousands of fibers that are bundled and encased at both ends in epoxy resin. The ends of the bundle are cut, which leaves the fiber bores open on both ends, allowing the gas to travel from one end to the other. The fiber bundle is enclosed in a suitable casing. The casing protects the fibers and routes the gas properly.

Benefits

Industrial Grade

PRISM PE3020 and PE3030 membrane dryers are constructed with heavy gauge ABS shells and aluminum caps which makes them extremely durable for applications where equipment is operating in all types of conditions. A stainless-steel shell option makes severe duty and corrosive applications, like off-shore and shipboard, possible without secondary containment.

Design Flexibility

Adjustable purge rates make the PE dryers a flexible choice for system designers. Dew point depressions are set by adjusting the sweep air flows. Compressed air dew points are optimized without wasting energy by over-drying. Three-port caps make connections easy in difficult applications.

Reliable Operation

PRISM membrane separators are field-proven in the most demanding applications and environments, like offshore platforms and mining operations.

PE3020-E1



Pressure Dew Point	Feed Flow	Outlet Flow	Outlet Purge	Pressure Drop
Feed air: 100 PSIG; 100°F; Pressure Dew Point 100°F				
40 °F	38.8 scfm	32.6 scfm	15.9 %	2.6 psi
20 °F	30.2 scfm	24.1 scfm	20.2 %	2.0 psi
0 °F	19.0 scfm	14.8 scfm	21.9 %	1.2 psi
-20 °F	12.8 scfm	9.7 scfm	24.0 %	0.8 psi
Feed air: 7 BARG; 35°C; Pressure Dew Point 35°C				
3 °C	18.6 nL/sec	15.8 nL/sec	15.2 %	0.17 bar
-10 °C	13.6 nL/sec	10.9 nL/sec	20.0 %	0.12 bar
-20 °C	8.9 nL/sec	7.0 nL/sec	21.5 %	0.08 bar
-30 °C	5.8 nL/sec	4.5 nL/sec	22.8 %	0.05 bar

PE3030-E1



Pressure Dew Point	Feed Flow	Outlet Flow	Outlet Purge	Pressure Drop
Feed air: 100 PSIG; 100°F; Pressure Dew Point 100°F				
40 °F	50.7 scfm	43.6 scfm	14.0 %	5.5 psi
20 °F	42.7 scfm	35.5 scfm	16.9 %	4.5 psi
0 °F	31.4 scfm	25.5 scfm	18.7 %	3.3 psi
-20 °F	25.3 scfm	20.1 scfm	20.7 %	2.6 psi
Feed air: 7 BARG; 35°C; Pressure Dew Point 35°C				
3 °C	24.4 nL/sec	21.1 nL/sec	13.3 %	0.36 bar
-10 °C	19.7 nL/sec	16.4 nL/sec	16.6 %	0.29 bar
-20 °C	15.0 nL/sec	12.3 nL/sec	18.2 %	0.22 bar
-30 °C	12.1 nL/sec	9.7 nL/sec	19.8 %	0.17 bar

Performance listed for single input pressure and operating temperature. Performance varies with compression and temperature of the feed air and sweep flows. Contact our Technical Services department to receive detailed performance recommendations or to generate simulations for your specific production requirements.

Feed Air Requirements

Pre-treatment steps differ by application but typically include coalescing filtration to remove particulates and liquid droplets, temperature control, and pressure control. Consult Design-and-Reference manual for detailed information associated with these products.

Materials

Shell tube: 4A/B/V, 6A/B/V	High Performance ABS
End caps: 4A/B/V, 6A/B/V	6061 T6 Aluminum
Shell tube: 6J	316L Stainless Steel
End caps: 6J	316L Stainless Steel

Mechanical Design Limits

Design Pressure	385 PSIG (26.5 BARG)
Design Temperature	150°F (65°C)

Typical Operating Range

Pressure	30 to 200 PSIG/ (2.1 to 13.8 BARG)
Temperature	-10°F to 150°F (-23°C to 65°C)

Dimensions

PE3020-3030 4A/4B

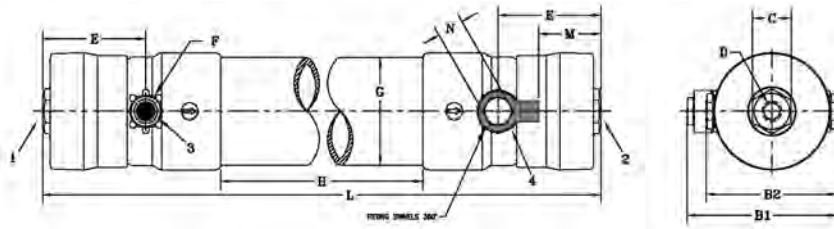

Ports:

1. Compressed Air Inlet
2. Dry Air inlet
3. Purge Outlet
4. Purge Inlet

Part No	Model No.	D	H	L	Weight	A	B1	B2	C	E	F	G	M	N
107072	PE3020-E1-4A-00	1/2" NPT	12.73" (323.3 mm)	26.88" (682 mm)	6.1 lb (2.76 kg)	3.91" (99.3 mm)	5.30" (134.6 mm)	4.63" (117.6 mm)	1.38" (35.1 mm)	4.13"±.06 (104.9 ± 1.5 mm)	3/8" NPT	3.50" (88.9 mm)	2.62" (66.5 mm)	0.875" (22.23 mm)
107073	PE3020-E1-4B-00	1/2" BSPP	12.73" (323.3 mm)	26.88" (682 mm)	6.1 lb (2.76 kg)									
107076	PE3030-E1-4A-00	1/2" NPT	27.10" (688.3 mm)	41.2" (1048 mm)	8.0 lb (3.62 kg)									
107077	PE3030-E1-4B-00	1/2" BSPP	27.10" (688.3 mm)	41.2" (1048 mm)	8.0 lb (3.62 kg)									

PE3020-3030-4U Three Port Caps

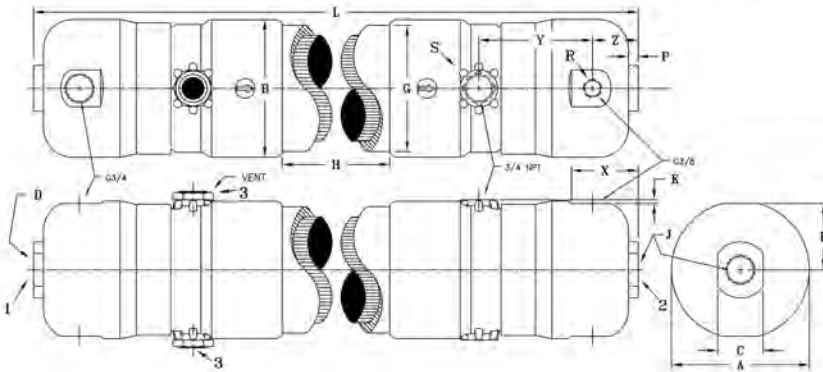

Ports:

1. Compressed Air Inlet
2. Dry Air Outlet
3. Purge Outlet
- S. Sweep Air Inlet

Part No	Model No.	D	H	L	Weight	A	B	C	E	F	G	J	K	P	X	Y	Z
493880	PE3020-E1-4V-00	1/2" BSPP	12.73" (323.3 mm)	28.9" (708.7 mm)	—	3.90–3.93" (99.2–99.8 mm)	3.88" (98.6 mm)	1.375–1.399" (34.9–35.5 mm)	1.88–1.90" (47.7–48.3 mm)	3/8" NPT	3.50" (88.9 mm)	1/2"–14 BSPP	0.04–0.08" (1.0–2.0 mm)	0.297–0.321" (7.55–8.16 mm)	2.03" (51.6 mm)	3.28"±0.06 (83.2 ± 1.5)	1.360" (34.5 mm)
495735	PE3030-E1-4V-00	1/2" BSPP	27.10" (688.3 mm)	42.2" (1073.1 mm)	—												

PE3020-6J Stainless Steel

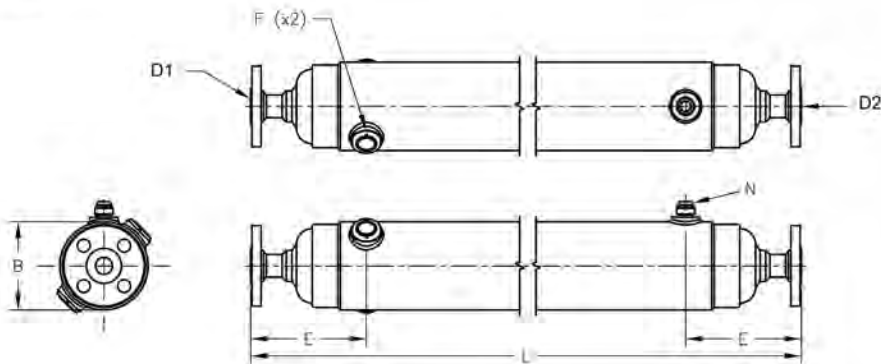

Ports:

- D1. Compressed Air Inlet
- D2. Dry Air Outlet
- N. Sweep Air Inlet
- F. Purge Air Outlet

Part No	Model No.	D	L	Weight	A	B	E	F	N
107075	PE3020-E1-6J-00	3/4" 150# RFSWF	29.75" (755.6 mm)	39.7 lb (18.0 kg)	5.56" (141.2 mm)	6.38" (162.1 mm)	5.56" ±.06 (141.2 ± 1.5 mm)	3/8" Vent	SAE J514 37° Flare 5/8" No. O.D. Tube



For more information regarding PRISM Membrane separators, please contact our Technical Services department.

Air Products PRISM Membranes
11444 Lackland Road
Saint Louis, Missouri 63146 USA
T: 1-314-995-3300
F: 1-314-995-3500
E: membrane@airproducts.com
airproducts.com/membranes

Permea China LTD
60 Jinshajiang Road
Shandong, 264006 China
T: +86-535-2165333
F: +86-535-2165336
E: fungp@airproducts.com
permea.com.cn

Air Products Japan K.K.
Kamiyacho Prime Place 9F
4-1-17 Toranomon, Minato-ku,
Tokyo 105-0001 JAPAN
T: +81-3-5405-6304
F: +81-3-5405-6301
E: higucht@airproducts.com

PRISM membrane separators are available through two channels:

Air Products Prism Membranes sells and distributes membrane separators through Original Equipment Manufacturing (OEM) arrangements. This global network of value-added-resellers integrates the PRISM Membrane gas separators into systems for a variety of applications, from food preservation to scuba diving air. If you have an interest in using PRISM membrane separators in your gas generation systems, please contact our Business Development specialists.

Fully-assembled membrane systems are available through the Air Products Engineered Systems group. Each nitrogen system is fabricated to the highest engineering classifications. These are the same nitrogen-membrane systems that Air Products uses in its own facilities, so you can be sure that the quality and performance meets the highest standards.

We look forward to working with you.

Reasons why our membrane separators are the best on the market

1. Low total costs

- Lowest air consumption membrane separator on the market across the widest portfolio of product offerings.
- Broad operating range enables flexible design and optimization.
- More than 35 years of experience designing the most cost effective systems.

2. Quality & Reliability

- USA-based manufacturing with quality systems certified to AS9100 and ISO9001 standards.
- Trusted in critical applications like aircraft fuel tank inerting, shipboard/offshore systems, and refinery operations.
- Longest demonstrated lifespan.

3. Technical Support

- Access to experts at membrane@airproducts.com or +1-314-995-3300.
- Specialized experience in troubleshooting and development support.
- Capabilities to customize or develop new membrane products.

The information contained in this document is believed to be true and accurate at time of publication. Air Products PRISM Membranes reserves the right to change product specifications without notification. Please consult current *Product Design and Reference* manual for detailed information associated with these products.

PRISM is a registered trademark of Air Products and Chemicals, Inc.



tell me more
airproducts.com/membranes